

EXPRESS CARD CONNECTOR

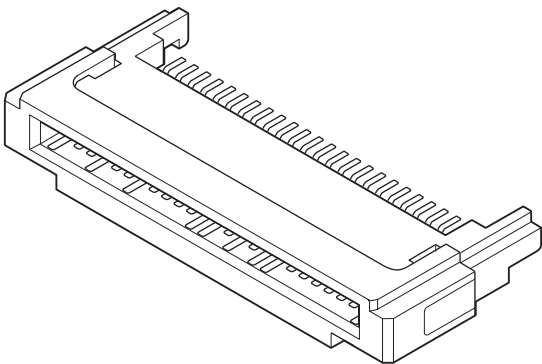

This is the module connector for Express Card complying with Express Card Standard Ver.1.0.



Features

- **Complying with PCMCIA Express Card Standard Ver.1.0**

This modular connector complies with PCMCIA Express Card Ver.1.0 which has been standardized as next generation of PC Card. It is registered as the Compliant Product in Web site of Express Card. Compliance ID: EC100017

- **Excellent durability**

In order to protect the mating pins at CF card side, the shutter locking mechanism is adopted.

- **Variation**

According to the customer's requirement, the off-set of connector solder tails is enabled.

Specifications

- Current rating: 0.75A AC, DC/line
 - Temperature range: 0°C to +55°C
(including temperature rise in applying electrical current)
 - Contact resistance: Initial value/40m Ω max.
After environmental testing/15m Ω max.
(variation from initial value)
 - Withstanding voltage: 500V AC/minute
 - Mating/unmating life: 10,000 cycles
 - Insertion loss: -1.7dB min. (3.125GHz)/-5.5dB min. (6GHz)
 - Return loss: -10dB max. (3.125GHz)/-5dB max. (6GHz)
 - Cross talk: -32dB max. (3.125GHz)/-26dB max. (6GHz)
- * Compliant with RoHS.
* Refer to "General Instruction and Notice when using Terminals and Connectors" at the end of this catalog.
* Contact JST for details.

EXPRESS CARD CONNECTOR

Module Connector

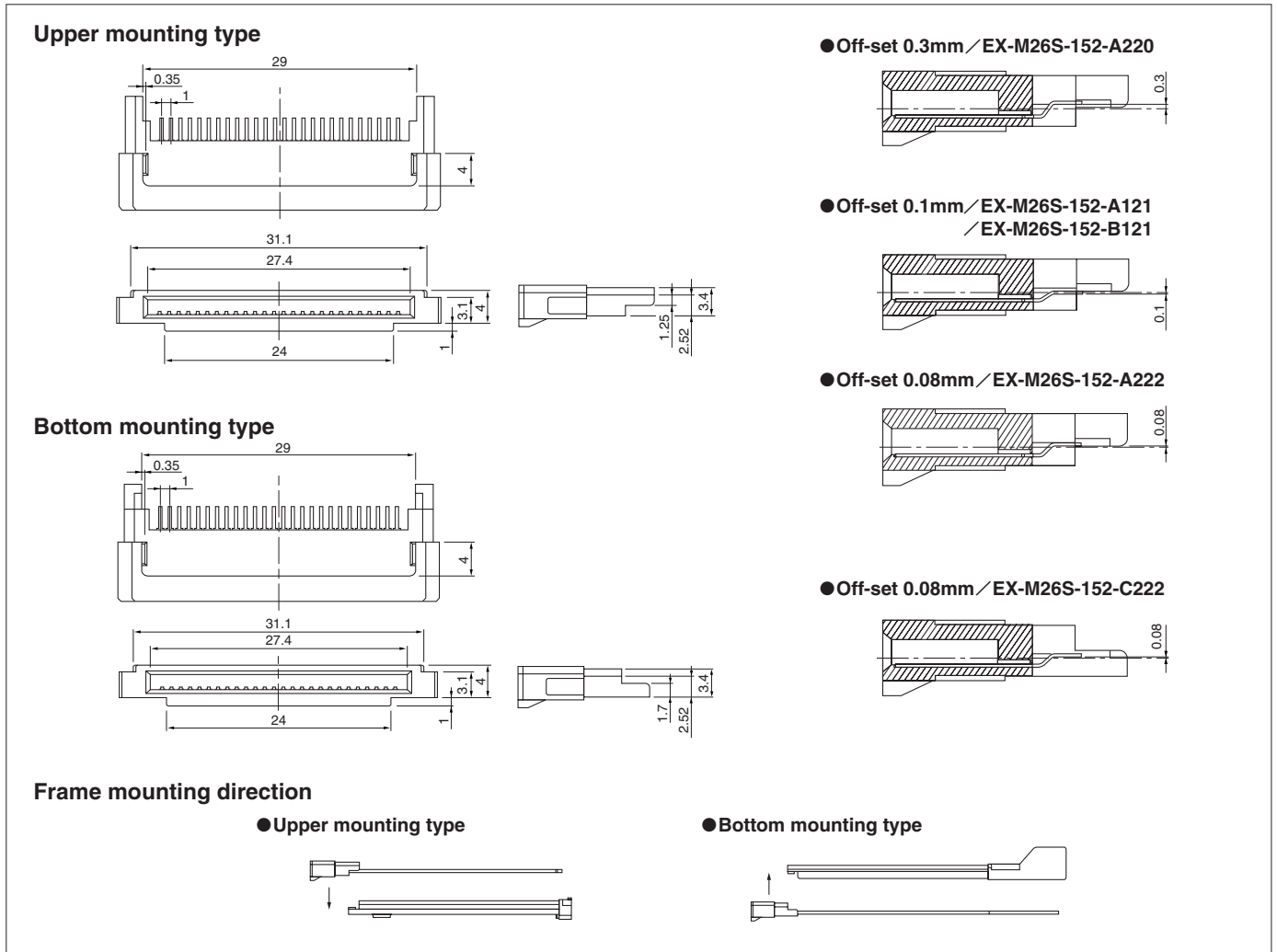

Circuits	Off-set size	Frame mounting type	Resin color	Model No.	Material and Finish	Q'ty/box
26	0.3	Upper side	Black	EX-M26S-152-A220	Contact: Copper alloy, nickel-undercoated, Mating part; gold-plated Solder tail; tin-plated (reflow treatment) Housing: LCP, UL94V-0, black	3,510
	0.1	Upper side	Black	EX-M26S-152-A121		
			Gray	EX-M26S-152-B121		
	0.08	Upper side	Black	EX-M26S-152-A222		
Bottom side		Black	EX-M26S-152-C222			

RoHS compliance This product displays (LF)(SN) on a label.

PC board layout (viewed from component side)

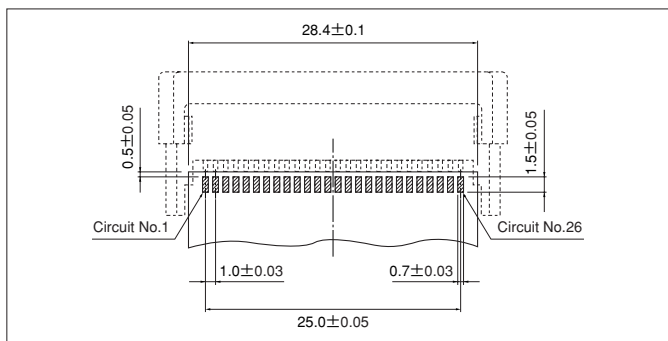

Note: 1. Tolerances are non-cumulative: $\pm 0.03\text{mm}$ for all centers.
2. The dimensions above should serve as a guideline. Contact JST for details.