

M 40 POWER CONNECTORS (SIZE 1,5)

Connector series M 40 is suitable for high current and is preferably used for heavy drive application. The high-quality housing out of metal fulfills all requirements, that are present in a rough industrial environment. Furthermore, it convinces through a long operational lifetime.

- // suitable for requirements with high current
- // safe EMC protection



Product overview

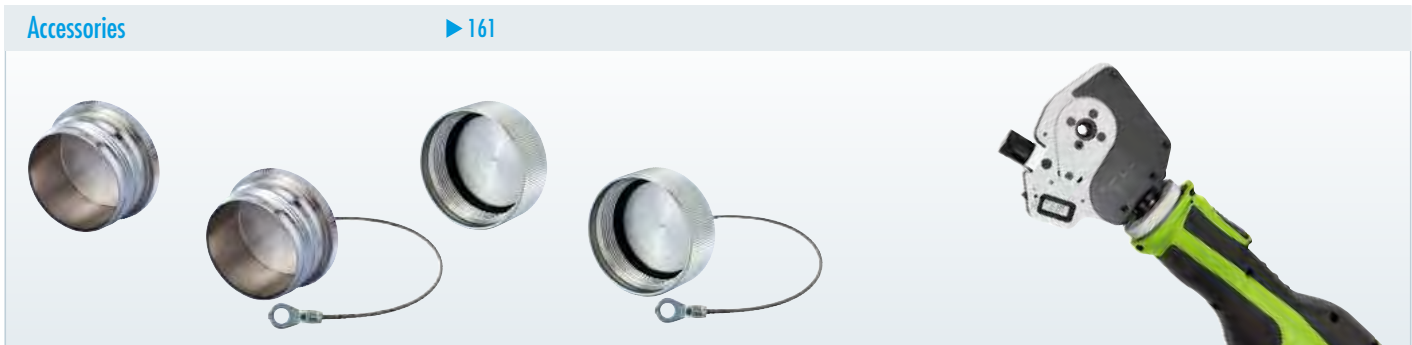

Mechanical Data	Materials and Technical Data
Housing	Copper-Zinc alloy Die Cast
Housing surface	Nickel plated, other surface upon request
Inserts (for contacts)	Thermoplastic Polyamid PA 6 (Nylon 6/6), PBT Fire protection class V-0
Contacts	Brass Alloy
Contact surface at point of contact	Nickel and gold plated (0,25 µm)
Minimum mating cycles	> 500
Seals / O-Rings	Buna-N standard optional Viton® (FKM / FPM) (Viton is a registered trademark of DuPont)
Temperature range	-40 °C – 125 °C (-40 °F – 257 °F)
Type of contacts	Crimp
Protection	IP 67 / IP 69K per EN 60 529 (connected), NEMA 4x
Cable diameter range	13 – 28 mm (.51" – 1.10")

Electrical Data	2 + 3 + PE		4 + 3 + PE	
Number of positions	2	4	4	4
Number of contacts	2	4	4	4
Contact-Ø [mm]	2	3,6	2	3,6
Nominal current ¹⁾ [A]	28	55	28	55
Nominal voltage ²⁾ [V~] Degree of Protection 3 ³⁾	300	600	300	600
Test voltage (Breakdown voltage) ⁴⁾ [V~]	2500	4000	2500	4000
Insulation resistance [Ω]	> 10 ¹³		> 10 ¹³	
Max. contact resistance [mΩ]	3	1	3	1



Standard delivery of M 40 (size 1,5) Power Connector include Contact Insert.

^{1), 2), 3), 4)} See Technical Information page 18



Housings

Straight Connector, Female Thread

Cable-Ø	Part Number
2 + 3 + PE, insert for sockets	
13 – 18 mm (.51 – .71")	7.710.623.000
17 – 24 mm (.67 – .97")	7.710.723.000
21 – 28 mm (.83 – 1.10")	7.710.823.000

Straight Connector, Female Thread

Cable-Ø	Part Number
4 + 3 + PE, insert for sockets	
13 – 18 mm (.51 – .71")	7.710.643.000
17 – 24 mm (.67 – .97")	7.710.743.000
21 – 28 mm (.83 – 1.10")	7.710.843.000

Straight Connector, Female Thread TWILOCK-S

Cable-Ø	Part Number
2 + 3 + PE, insert for sockets	
<i>* intermateable with Speedtec</i>	
13 – 18 mm (.51 – .71") ¹⁾	7.716.623.00S
17 – 24 mm (.67 – .97") ¹⁾	7.716.723.00S
21 – 28 mm (.83 – 1.10") ¹⁾	7.716.823.00S

Straight Connector, Female Thread TWILOCK-S

Cable-Ø	Part Number
4 + 3 + PE, insert for sockets	
<i>* intermateable with Speedtec</i>	
13 – 18 mm (.51 – .71") ¹⁾	7.716.643.00S
17 – 24 mm (.67 – .97") ¹⁾	7.716.743.00S
21 – 28 mm (.83 – 1.10") ¹⁾	7.716.843.00S

¹⁾ under development

Straight Connector, Male Thread TWILOCK-S*

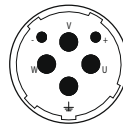
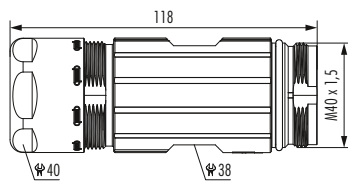

Cable-Ø

Part Number

Cable-Ø	Part Number
2 + 3 + PE, insert for pins	
13 – 18 mm (.51 – .71")	7.720.623.000
17 – 24 mm (.67 – .97")	7.720.723.000
21 – 28 mm (.83 – 1.10")	7.720.823.000
* intermateable with Speedtec	
13 – 18 mm ¹⁾	7.720.623.00S
17 – 24 mm ¹⁾	7.720.723.00S
21 – 28 mm ¹⁾	7.720.823.00S



Straight Connector, Male Thread TWILOCK-S*

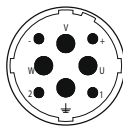
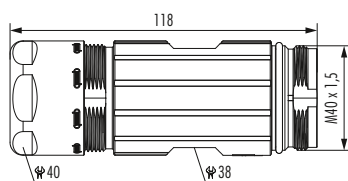

Cable-Ø

Part Number

Cable-Ø	Part Number
4 + 3 + PE, insert for pins	
13 – 18 mm (.51 – .71")	7.720.643.000
17 – 24 mm (.67 – .97")	7.720.743.000
21 – 28 mm (.83 – 1.10")	7.720.843.000
* intermateable with Speedtec	
13 – 18 mm ¹⁾	7.720.643.00S
17 – 24 mm ¹⁾	7.720.743.00S
21 – 28 mm ¹⁾	7.720.843.00S



Panel Connector, Male Thread, Front Mounting TWILOCK-S*

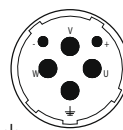
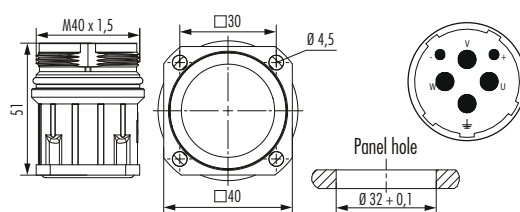

Type

Part Number

Type	Part Number
2 + 3 + PE, insert for pins	
4 holes Ø 4,5 mm (.18")	7.740.023.000
* intermateable with Speedtec	
4 x Bohr. 4,5 mm ¹⁾	7.740.023.00S



Panel Connector, Male Thread, Front Mounting TWILOCK-S*

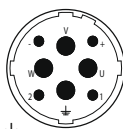
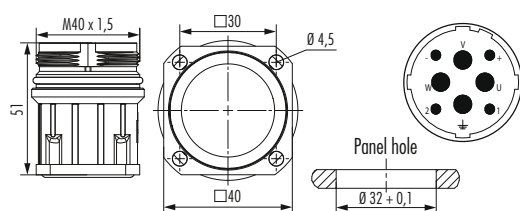

Type

Part Number

Type	Part Number
4 + 3 + PE, insert for pins	
4 holes Ø 4,5 mm (.18")	7.740.043.000
* intermateable with Speedtec	
4 x Bohr. 4,5 mm ¹⁾	7.740.043.00S





¹⁾ under development

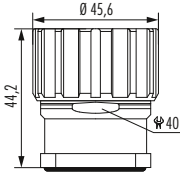
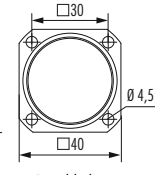

Housings

Panel Connector with knurled Nut, Front Mounting







Panel hole
Ø 32 + 0,1

Type	Part Number
2 + 3 + PE, insert for sockets 4 holes Ø 4,5 mm (.18")	7.744.023.000

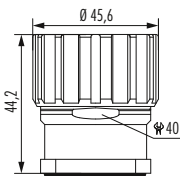
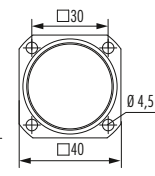
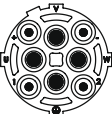

Panel Connector with knurled Nut, Front Mounting







Panel hole
Ø 32 + 0,1

Type	Part Number
4 + 3 + PE, insert for sockets 4 holes Ø 4,5 mm (.18")	7.744.043.000

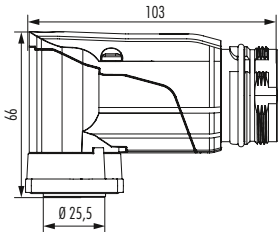
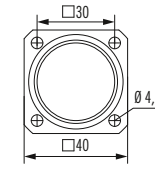
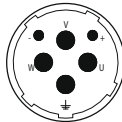

Right Angle Panel Connector, Male Thread, rotatable TWILOCK-S*







Panel hole
Ø 32 + 0,1

Type	Part Number
2 + 3 + PE, insert for pins * intermateable with Speedtec 4 holes Ø 4,5 mm (.18")	7.749.023.005

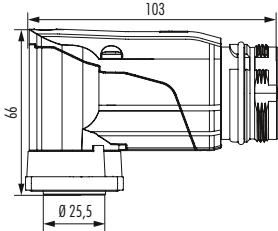
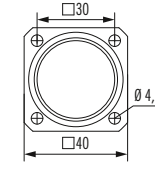
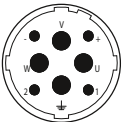

Right Angle Panel Connector, Male Thread, rotatable TWILOCK-S*

Panel hole
Ø 32 + 0,1

Type	Part Number
4 + 3 + PE, insert for pins * intermateable with Speedtec 4 holes Ø 4,5 mm (.18")	7.749.043.005



¹ under development



Panel Connector, Male Thread, Single Hole Mounting		Type	Part Number
		Front mounting, 2 + 3 + PE, insert for pins	
		Thread M 40 x 1,5	7.742.023.000

Panel Connector, Male Thread, Single Hole Mounting		Type	Part Number
		Front mounting, 4 + 3 + PE, insert for pins	
		Thread M 40 x 1,5	7.742.043.000

Contact Arrangement, Mating View	Number of Poles	Required Contacts
	Insert for pins 2 + 3 + PE	2 x crimp pins 2 mm
	4 x crimp pins 3,6 mm
	Insert for sockets 2 + 3 + PE	2 x crimp sockets 2 mm
	4 x crimp sockets 3,6 mm
	Insert for pins 4 + 3 + PE	4 x crimp pins 2 mm
	4 x crimp pins 3,6 mm
	Insert for sockets 4 + 3 + PE	4 x crimp sockets 2 mm
	4 x crimp sockets 3,6 mm

Standard delivery of M 40 (size 1,5) Power Connector include Contact Insert.







Contacts

Contacts	Type	Crimp Range	Part Number
	Crimp pin 2 mm, machined	0,25 – 1 mm ² (AWG 24 – 17)	7.015.952.003 ¹
	Crimp pin 2 mm, machined	1 – 4 mm ² (AWG 17 – 12)	7.015.952.001
	Crimp socket 2 mm, machined	0,25 – 1 mm ² (AWG 24 – 17)	7.015.952.004 ¹
	Crimp socket 2 mm, machined	1 – 4 mm ² (AWG 17 – 12)	7.015.952.002
	Crimp pin 3,6 mm, machined	1,5 – 4 mm ² (AWG 16 – 12)	7.015.953.601
	Crimp socket 3,6 mm, machined	1,5 – 4 mm ² (AWG 16 – 12)	7.015.953.602
	Crimp pin 3,6 mm, machined	6 mm ² (AWG 10)	7.015.953.611
	Crimp socket 3,6 mm, machined	6 mm ² (AWG 10)	7.015.953.612
	Crimp pin 3,6 mm, machined	AWG 8	7.015.953.621
	Crimp pin 3,6 mm, machined	10 mm ²	7.015.953.623
	Crimp socket 3,6 mm, machined	AWG 8	7.015.953.622
	Crimp socket 3,6 mm, machined	10 mm ²	7.015.953.624
	Crimp pin 3,6 mm, machined	16 mm ² (AWG 6)	7.015.953.631
	Crimp socket 3,6 mm, machined	16 mm ² (AWG 6)	7.015.953.632

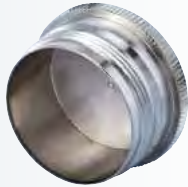

¹ under development

Accessories	Type	Part Number
	Plastic protective cap for connectors with female thread	7.000.900.152
	Plastic protective cap for connectors with male thread	7.000.900.151
	Brass protective cap for connectors with female thread	7.015.900.103 ¹
	Brass protective cap for connectors with male thread	7.015.900.102
	Brass protective cap with rope for connectors with female thread	7.015.9S1.003 ¹
	Brass protective cap with rope for connectors with male thread	7.015.9S1.002
	Adaptor flange for Straight Connectors	7.010.900.129 ¹

¹ No compatibility with TWILOCK



Accessories

Accessories	Type	Part Number
	Adapter for Conduit Fittings	
	Poleon DN 23	7.010.900.215
	Poleon DN 29	7.010.900.217
	Manual crimp tool	
	machined crimp contacts until 10 mm ² (AWG 8) for power connectors	
	battery pack crimp tool for connectors M 40 (European market only)	7.000.900.920
	crimping unit for crimp tool	7.000.900.919
	locator for 3,6 mm contacts at crimp tool	7.010.900.153
	assembly instructions online: www.hummel.com	
	Crimp tool for manual crimping	
	of machined crimp contacts 16 mm ² (AWG 6)	7.000.900.903



Crimp Tool Setting for HUMMEL Crimp Contacts (Crimp Tool 7.000.900.920)

Part Number	Crimp Contact	Cross Section (mm ²)	AWG	Crimp Tool Setting mm	Locator Setting
7.015.952.001	Crimp pin 2 mm	0,75	18	1,31 mm	3
		1	17	1,38 mm	3
		1,5	16	1,45 mm	3
		2,5	14	1,50 mm	3
		4	12	1,60 mm	3
7.015.952.002	Crimp socket 2 mm	0,75	18	1,31 mm	4
		1	17	1,38 mm	4
		1,5	16	1,45 mm	4
		2,5	14	1,50 mm	4
		4	12	1,60 mm	4
7.015.953.601	Crimp pin 3,6 mm	2,5	14	1,4	1
		4	12	1,6	1
7.015.953.602	Crimp socket 3,6 mm	2,5	14	1,4	2
		4	12	1,6	2
7.015.953.611	Crimp pin 3,6 mm	6	10	1,8	1
7.015.953.612	Crimp socket 3,6 mm	6	10	1,8	2
7.015.953.621	Crimp pin 3,6 mm		8	2,6	1
7.015.953.622	Crimp socket 3,6 mm		8	2,6	2
7.015.953.623	Crimp pin 3,6 mm	10		2,7	1
7.015.953.624	Crimp socket 3,6 mm	10		2,7	2



These values are only guidelines and actual conductor cross sections depend on manufacturer tolerances.

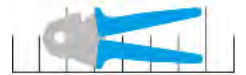

Crimp Tool Setting for HUMMEL Crimp Contacts (Crimp Tool 7.000.900.903)

Part Number	Crimp Contact	Cross Section (mm ²)	AWG	Crimp Tool Setting
7.015.953.631	Crimp pin 3,6 mm	16	6	die 16
7.015.953.632	Crimp socket 3,6 mm	16	6	die 16

These values are only guidelines and actual conductor cross sections depend on manufacturer tolerances.



Crimp Tool for M 40 Power Connectors (Size 1,5)

Crimp Tool

Type

Part Number

Crimp Tool for contacts 16 mm² (AWG 6)7.000.900.903

Application

The hand crimp tool 7.000.900.903 has been developed for optimal crimping of a large variety of connectors and terminals by using different interchangeable crimping dies.

Operation

- // Select crimp insert and install in tool
- // Insert and align crimp contact in tool
- // Compress tool until contact is held in place
- // Insert conductor into contact
- // Fully compress tool (tool will reopen automatically)
- // Remove crimped conductor from tool

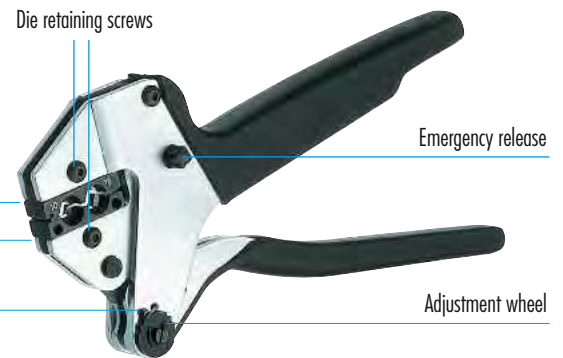

Stationary jaw with upper die

Movable jaw with lower die

Set screw

Die retaining screws

Emergency release

Adjustment wheel



Crimp Tool for M 40 Power Connectors (Size 1,5)

Crimp Tool



Adjustment of crimp force and height

Crimp force adjustment is done in the factory (120 – 180 N when unloaded). Tool frame and jaws are connected that way, an optimal crimping result will be obtained based on the hand force indicated above. In case the result (e.g. crimp height, pull-out force, etc.) does not meet the requirements of the plug manufacturer, the following reasons can be considered:

a) Normal wear of tool

Readjustment possible

b) Worn dies

Dies have to be replaced

The quality personnel is authorized to control and readjust these parameters as described below:

Unscrew the set screw by means of a screw driver

// Rotatable the adjustment wheel anticlockwise, the crimp force increases and the crimp height decreases (+)

// Rotatable the adjustment wheel lockwise, the crimp force decreases and the crimp height increases (-)

// When readjusting the hand force shall not exceed 180 N

// Before using the tool, the operator has to check the adjustment wheel being firmly secured by the set screw

Maintenance

Keep the tool clean and properly stored when not in service. The joints need to be regularly oiled and the circlips securing the bolts have to be always in place. Never use abrasives or hard material to clean the jaws. Please contact the manufacturer when the tool needs to be repaired or in case of readjustment problems.



Straight Connector, Female Thread / Male Threaded Connector

1.

max. 40 mm
2.

x
3.

⚠ x

Contact ø 2 mm = max. 7 mm stripping length
Contact ø 3,6 mm = max. 10 mm stripping length
4.

crimp

click
5.

click
6.

scissors
7.

40

38



Assembly Instructions

Panel Connector

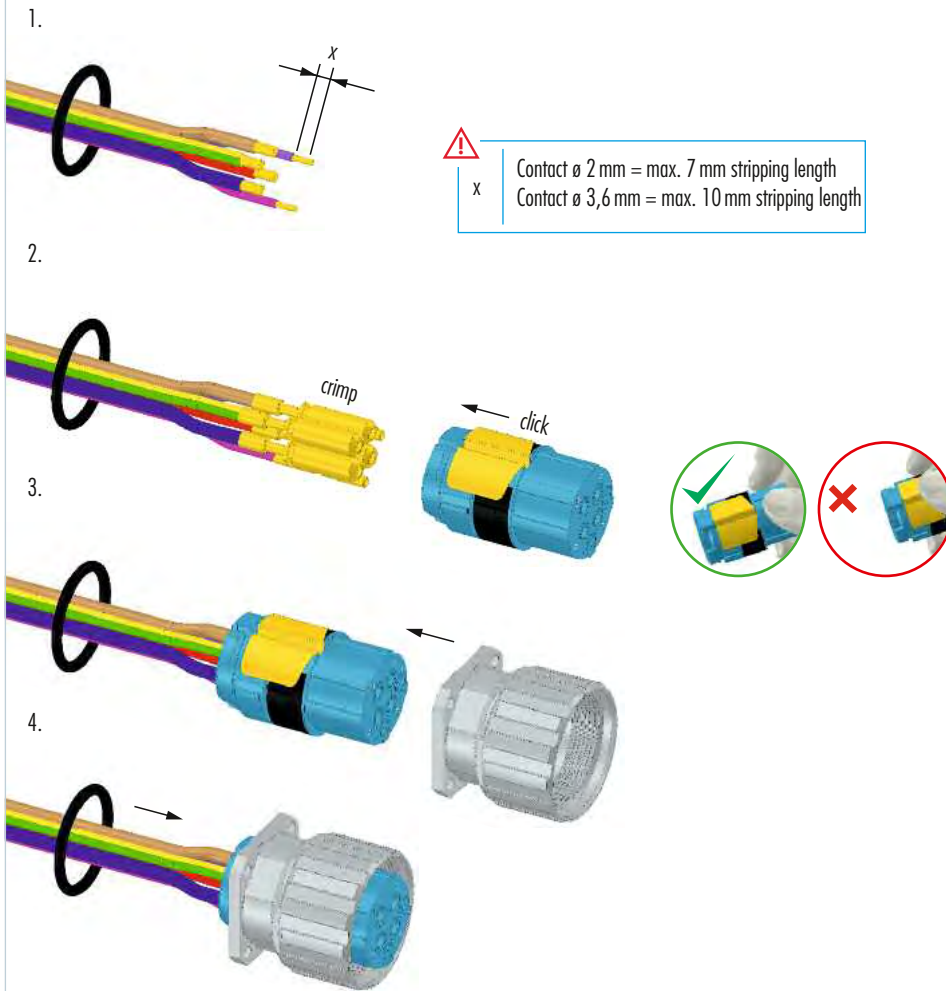



Right Angle Panel Connector

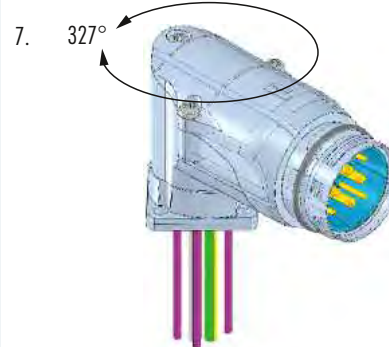
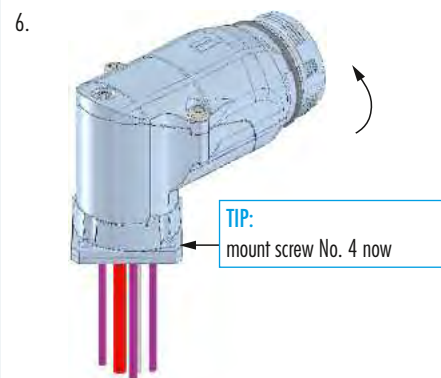
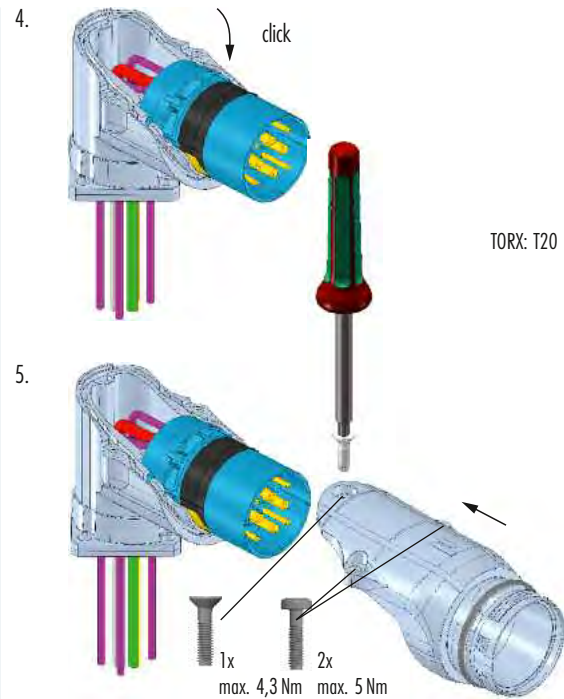
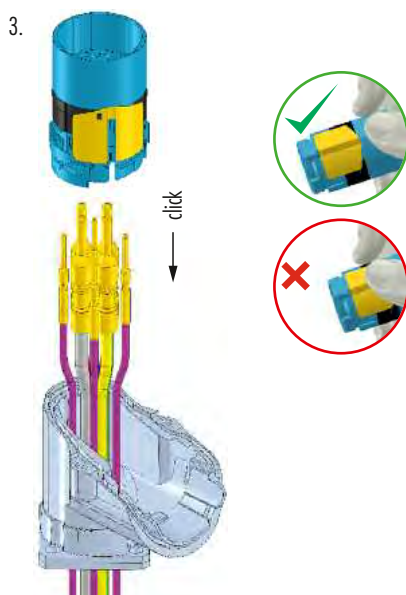
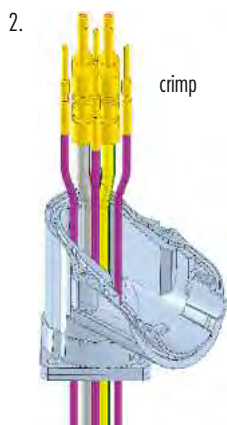
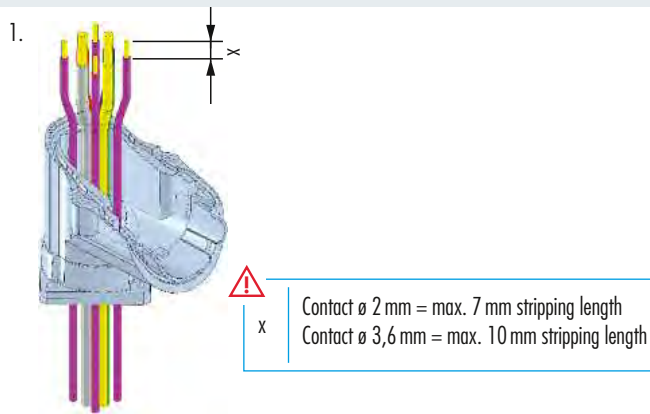



Crimping, Assembly and Disassembly of Contacts



Crimping

- // For 2 mm contacts strip wire ends 7 mm (.28"), for 3,6 mm contacts strip wire ends 10 mm (.39")
- // Dial appropriate setting of crimp tool
- // Push crimp contact into opening of crimping tool
- // Insert stripped wire into the funnel shaped end of the crimp contact
- // Squeeze handles of crimping tool together connect contact to wire

Assembly

Remove crimped assembly and pull on wire to test connection. Push into desired position of insert.
 Note: It is recommended to assemble the large contacts first.

Disassembly of Contacts from Insert

A small screwdriver is needed to remove the contacts from the insert.

- // Release the white ring by a screwdriver out of the insert
- // Move the misplaced contacts out of the insert
- // Enter the ring back into the insert
- // Push the contacts back into insert

Shielding

- // Assemble strain relief insert with insert
- // Fold stranding of the shield back over the first O-Ring of the strain relief insert
- // Cut back the overextending braid



The stranding of the shield is not allowed to touch the second O-Ring. Otherwise the assembly may not be proof.