

REV.:X1

| ECN. NO. | REV. | DATE | DESCRIPTION | CHANGE | APPD. |
|----------|------|------------|-----------------|--------|-------|
| | x1 | 08/05'2016 | INITIAL RELEASE | / | |

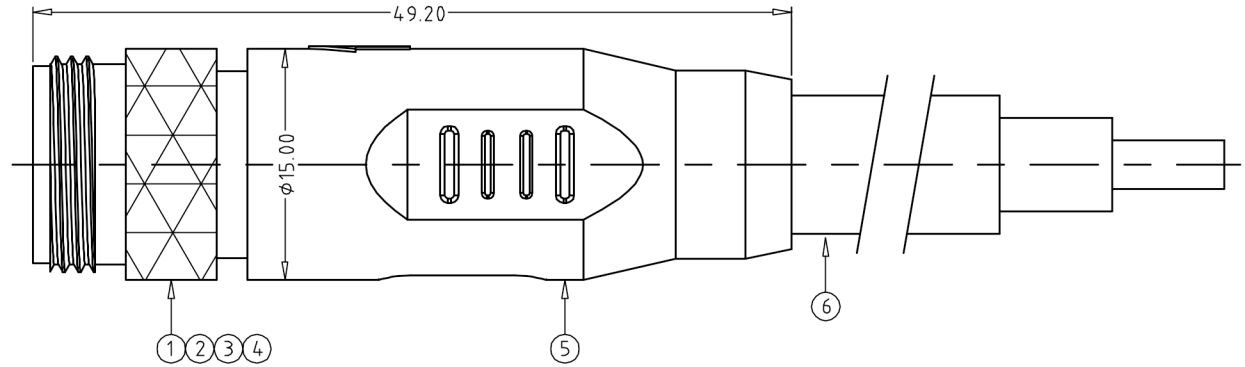
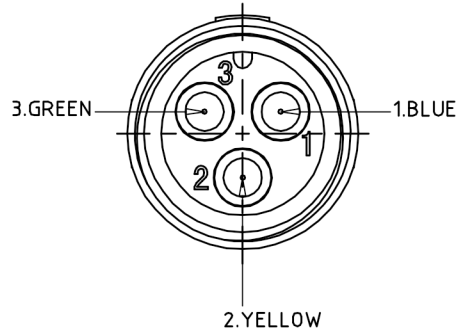

| | | |
|----------|--|------|
| 6 | 3 POLE CABLE, $\phi 9.0, 3 \times 4.0 \text{mm}^2$, TINNED COPPER, TEFLON INSULATION(200℃), PVC JACKET(105℃), BLACK COLOR | 1PCS |
| 5 | L315 CONNECTOR JACKET PVC(105℃), SHORE HARDNESS 95A UL94V-0, BLACK COLOR | 1PCS |
| 4 | BRACKET, PBT+30% GF(120℃) UL94V-0, BLACK COLOR | 1PCS |
| 3 | INSULATOR, PBT+30% GF(120℃) UL94V-0, BLACK COLOR | 1PCS |
| 2 | BOLT, M14×1.0, BRASS (GB HPB-59-1), FULL NICKEL PLATED 200u"MIN | 1PCS |
| 1 | CONTACT PIN, $\phi 2.50$, BRASS (GB HPB-59-1), 4u" MIN GOLD PLATING OVER ALL 50~100u" NICKEL UNDER PLATING OVER ALL | 3PCS |
| item no. | Specification | QTY |

- Electrial Characteristics:
 - Low level contact resistance: 10 milliohm Max.
 - Dielectric withstanding voltage: 700VAC.
 - Insulation resistance: 20 megaohm Min.
 - Mechanical Characteristics:
 - Mating cycle: 200 cycle.
 - Performance:
 - Voltage rating: 48V AC, 60V DC.
 - Current rating: 45Amps
 - Operation temperature: $-25^{\circ}\text{C} \sim +80^{\circ}\text{C}$.
 - Requirement:
 - Environmental pratection, accord ROHS 2.0.
 - Applicable wire:
 - $\phi 2.5$ Contact: 4.0mm² MAX.
 - Degree of protection:
 - IP67 in locked condition
- Order code: L315AG P 01 B8 1000**

| | | | | | | | | | |
|------------|---|----------------------------|---|-------|-------|------|-----|-----|--|
| MAT'L: | 上海海固电器设备有限公司 Shanghai Higo Electronic Technology Co., Ltd. | | | | | | | | |
| UNITS: | TITLE: | PART NO.: | | | | | | | |
| mm | L315 MALE | F03MTA37-L150 | | | | | | | |
| X.±: 5 | X°.±: 5° | DWG NO.: | | | | | | | |
| .X±: 1 | .X°.±: 2° | E-F03MTA37-00 | | | | | | | |
| .XX±: 0.30 | .XX°.±: 1° | DRAW: Gary zhou 08/05'2016 | <table border="1"> <tr> <td>SCALE</td> <td>SHEET</td> <td>REV.</td> </tr> <tr> <td>N/A</td> <td>1/1</td> <td></td> </tr> </table> | SCALE | SHEET | REV. | N/A | 1/1 | |
| SCALE | SHEET | REV. | | | | | | | |
| N/A | 1/1 | | | | | | | | |